

# FPGA Implementation of Neuro-Fuzzy based Inverter

Prof. Nilesh N. Kasat    Dr. M. S. Ali    Er. Dharmik N. Mehta

**Abstract**—The DC-AC converter, also known as the inverter, converts DC (Direct Current) power to AC (Alternating Current) power at desired output voltage and frequency. The inverter therefore is an adjustable-frequency voltage source. The project aims to design a FPGA implement Neuro-Fuzzy based 1- $\phi$  square wave voltage source inverter using Pulse Width Modulation (PWM) switching scheme to supply AC utilities with emergency power. A model of the voltage source Inverter using a pair of MOSFETs and a driver circuit is designed; then to increase its performance, a fuzzy controller (FC) which its parameters are adjusted by a basis neural network (NN) function. The VHDL (VHSIC Hardware Description Language) code for the system was written and behavioral simulation was performed on the architecture whose results were seen in ModelSim software. After verifying the results this VHDL code was downloaded to ALTERA FPGA (Field Programmable Gate Array) and synthesized using Quartus II software. After downloading the code in FPGA real time debugging was done for the architecture. The focus is on designing an inexpensive, versatile and power efficient square wave inverter that gives a square wave AC output.

**Keywords**-MOSFETs, PWM Inverter, Neuro-Fuzzy System, VHDL, FPGA

## I. INTRODUCTION

DC-AC converters are known as inverters. The function of an inverter is to change a DC voltage to a symmetric AC output voltage of desired magnitude and frequency. Some typical applications are variable speed AC drives, induction heating, standby power supplies, uninterruptible power supplies (UPS), traction, HVDC and so forth [11].

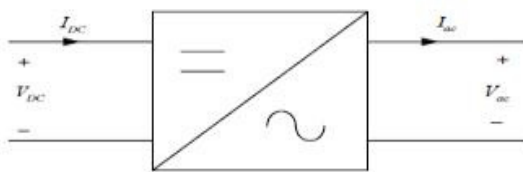

**Figure 1: General Block Diagram of Inverter**

Inverters can be broadly classified into two types such as single phase inverters and three phase inverters. The output voltage could be fixed or variable at a fixed or variable frequency. A variable output can be obtained by varying the input DC voltage and maintaining the gain of the inverter constant. The output waveforms of an ideal inverter should be sinusoidal. Due to the availability of high speed power semiconductor devices, the harmonic contents of output voltage can be minimized or reduced significantly by switching technique. BJTs, MOSFETs or IGBTs can be used as ideal

switches to explain the power conversion techniques. MOSFETs have high input impedance and low on state conduction losses. Also a MOSFETs in its enhanced mode drop less voltage than other semiconductor devices. Thus, improve power efficiency of the system.

## II. LITERATURE REVIEW

Power conversion (DC-AC conversion) has been increasingly used in many fields, due to its properties regarding high voltage capability and high power quality. But in industrial applications, there are many uncertainties, such as system parameter uncertainty, external load disturbance etc. which always diminish the performance quality of the design system. To cope with this problem, in past years, many intelligent control techniques [1-8] such as Digital Signal Processor (DSP) or Microprocessor, Microcontroller, Proportional-Integral-Derivative (PID), Artificial Neural Networks (ANN), Fuzzy Logic control (FLC) and other control method, have been developed to obtain high operating performance. Lately, the FPGA has drawn much attention in the development of electronics circuit control scheme due to its shorter design cycle, lower cost and higher density [10].

Some of intelligent control techniques for PWM Inverter (DC-AC conversion) are discussed:

In this paper the single phase SPWM microcontroller-based 300VA inverter is designed and tested for fixed modulation index 0.6 and unipolar voltage switching [1]. It was found that it gives maximum efficiency for 80W load up to 89%. and simulate this unipolar switching model in MATLAB. A single phase PWM voltage source inverter has been implemented with PIC16F73 microcontroller and gate driver's IC TLP250, totem-pole [2]. Several outstanding features are: fewer harmonic, low cost, simple, compact and used for low power and low voltage application such as light, fan, chargers, television etc.

A design and implement action of a single chip DSP-based (TMS320C14) fully digital-controlled single-phase pulse width modulated (PWM) dc-to-ac converter for AC voltage regulation is described [3]. The constructed ac-dc converter system can achieve fast dynamic response and with low total harmonic distortion (THD) for rectifier type of loads.

Design the PWM inverter control IC and implemented using a single FPGA XC4005 from Xilinx, Inc., in application of ac-voltage regulation [4]. A multiple-loop control scheme is proposed to achieve sinusoidal voltage regulation under large load variations.

The design and implementation of a sinusoidal PWM generator for a single-phase hybrid power filter is presented [5]. It was developed in an Altera® Flex 10 K FPGA and the modulation index was selected by calculating the DC bus

voltage of the active filter through a digital controller, by Proportional-Integral-Derivative (PID) technique.

FPGA based Fuzzy Logic Control for Single Phase PWM Multilevel Inverter (MLI) produces AC output voltage of desired magnitude and frequency [6]. Here, the objective of reducing the THD of output under steady-state as well as set point tracking with fast transient response is approached from control point of view. A FLC is developed using Matlab-Simulink and implemented using FPGA. In this paper, direct torque control (DTC) of induction motor (IM) using intelligent techniques: ANN and FLC is purposed [7]. The results of Matlab-simulink simulations are presented which shows that the direct torque control using fuzzy logic scheme is best for control of induction motor. The model used consists of an adaptive neuro-fuzzy inference system modified for efficient HW/SW implementation [8]. The designs of two different on-chip approaches are presented. The device contains an embedded-processor core and a large FPGA.

A high-frequency PWM generator architecture for power converter control, using FPGA and CPLD ICs, has been presented [9]. The proposed architecture is based on a special design synchronous binary counter and can be easily interfaced to a microcontroller or DSP system. The simulation results prove that using the proposed method, PWM frequencies up to 3.985 MHz can be produced with a duty cycle resolution of 1.56%, which is adequate for most applications. This paper presents an FPGA based gate signal generator for single phase multilevel inverter employing an sinusoidal PWM switching strategy to control its output voltage [10].

### III. THE PROPOSED FPGA BASED ARCHITECTURE

#### 3.1 Proposed Block Diagram:

This section presents the work using ALTERA FPGA system for single phase half-bridge type MOSFETs inverter. FPGA usually include on-chip PWM controllers making implementation easy. Hence the real time implementation of neuro-fuzzy controllers for chosen inverter using FPGA is carried out in this work. Multicarrier PWM generation and also the control strategies for the chosen inverter are developed using system generator software of Quartus II Software.

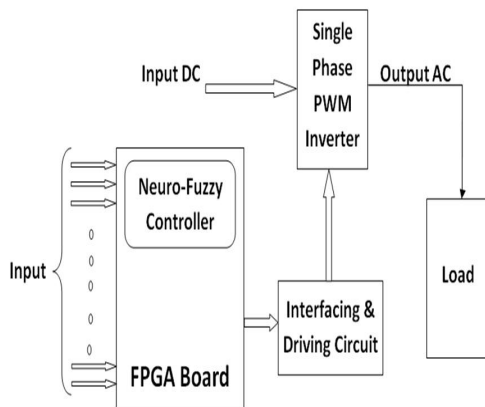
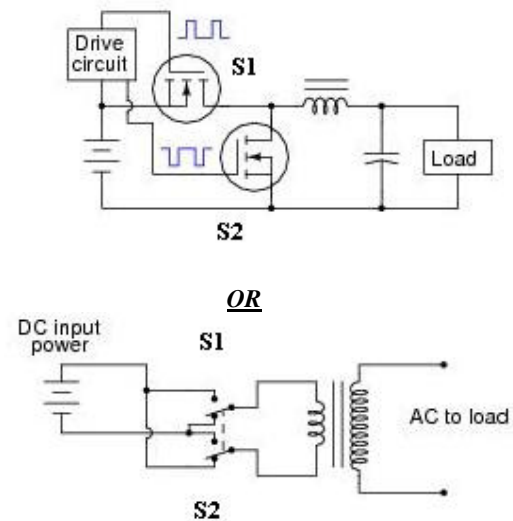

**Figure 3.1: Diagrammatic representation of the proposed work**

A VHDL codes are downloaded from the host computer into the FPGA chip using a USB cable. Then, Edge connector is used to interface the board (NF controller) with model of the Inverter. The digital input with switches has been applied as input data to the FPGA boards. The FPGA board generates the digital inputs to the NF controller. The NF controller generates a suitable digital control signal based on the rules that were stored in the FPGA chip. The digital control signal generates pulse waveform (PWM) and pulse waveform will be applied as an input to the 1- $\phi$  Half-Bridge MOSFET based PWM Inverter for controlling the gate trigger of the semiconductor device. The width of the pulse waveform is under control. Thus based on the application, a pulse waveform of different duty cycles is able to produce. Finally, the output we get is an AC type which is used to drive multiple AC loads.

In addition to FPGA, ModelSim SE 6.3f software was used for simulation and verification of the proposed circuit was done before implementation. Simulation results obtained is compared with the experimental results.

#### 3.1.1 1- $\phi$ Half-Bridge MOSFET drive Inverter:

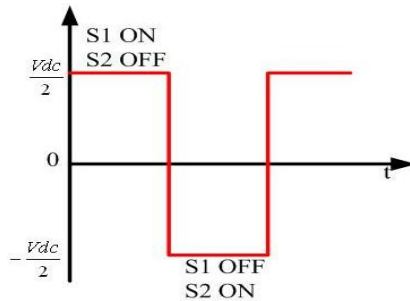

**Figure 3.1.1: Circuit Schematic**

Figure 3.1.1 shows the circuit schematic of 1- $\phi$  Voltage Source Half-Bridge MOSFET drive Inverter. It is also known as "Inverter Leg". There are 2 MOSFETs act as a switch (S1, S2). The DC source voltage is divided into two parts with the capacitors. Each capacitor has the same value and has voltage  $V_{dc}/2$ . ( $V_{rms} = V_{dc}/2$ ) The top(S1) and bottom(S2) switch must be complementary to each other. (When S1 is closed, S2 must be opened and vice versa). Feedback (freewheeling) diodes are required across the MOSFETs to provide continuity of current for inductive loads. It provides current to flow even when switches are opened.

Switching Device State		Output Voltage	Output Current	Conducting Semiconductor
S1	S2	$V_o$		

ON	OFF	Vdc/2	Positive	S1
OFF	ON	- Vdc/2	Positive	S2

**Table 3.1.1: Modes of operation**

**Figure 3.1.2: Inverter Output**

### 3.1.2 Neuro-Fuzzy Systems:

- ❖ **Neural Networks:** The neural networks try to shape the biological functions of the human brain. This leads to the idealization of the neurons as discrete units of distributed processing. The main characteristic of the neural networks is the fact that these structures can learn with examples (training vectors, input and output samples of the system). The neural networks modifies its internal structure and the weights of the connections between its artificial neurons to make the mapping, with a level of acceptable error for the application, of the relation input/output that represent the behavior of the modeled system.
- ❖ **Fuzzy Systems:** Fuzzy systems propose a mathematic calculus to translate the subjective human knowledge of the real processes. This is a way to manipulate practical knowledge with some level of uncertainty.
- ❖ **Neuro-Fuzzy Systems:** A lot of research is devoted to improve the ability of fuzzy systems, such as evolutionary strategy and neural networks. The combination of fuzzy logic and neural networks is called neuro-fuzzy system.

**Neuro-Fuzzy System (NFS) = Neural Network (NN) + Fuzzy Logic (FL)**

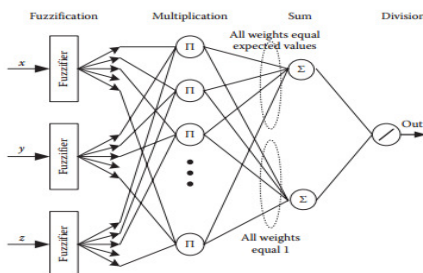
A NFS is a fuzzy system that uses a learning algorithm derived from or inspired by neural network theory to determine its parameters (fuzzy sets and fuzzy rules) by processing data samples. Figure 3.1.2 shows the neuro-fuzzy system which attempts to present a fuzzy system in a form of neural network.

**Figure 3.1.2: Neuro-Fuzzy System**

The neuro-fuzzy system consists of four blocks: Fuzzification, Multiplication, Summation, and Division. Fuzzification block translates the input analog signals into

fuzzy variables by membership functions. Then, instead of MIN operations in classic fuzzy systems, product operations (signals are multiplied) are performed among fuzzy variables. This neuro-fuzzy system with product encoding is more difficult to implement, but it can generate a slightly smoother control surface. The summation and division layers perform defuzzification translation. The weights on upper sum unit are designed as the expecting values (both Mamdani and TSK rules can be used); while the weights on the lower sum unit are all "1"

## IV. RESULT & DISCUSSION

### 4.1 Design Flow:

Fig 4.1 shows the sequence of steps followed when implementing 1- $\phi$  Voltage source half-bridge MOSFET drive PWM Inverter design on FPGA board.

FPGA is chosen for the hardware implementation of switching strategy mainly due to its high computation speed that can ensure the accuracy of the instants that gating signals are generated. VHDL language is used to model the inverter switching strategies.

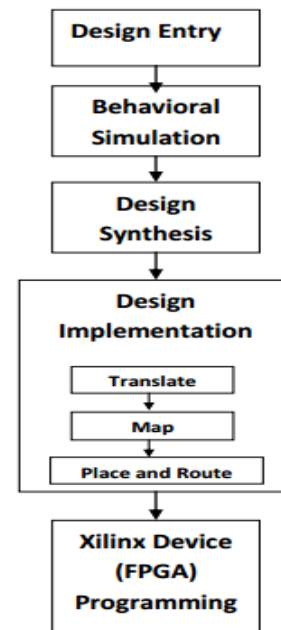
**Figure 4.1 Design Flow**

FPGA enables to make easy, fast and flexible design and implementation. After HDL designing, the code is simulated and its functionality is verified using ModelSim SE 6.3f simulation software. The code is simulated and the output is tested for the various inputs frequency i.e. for different duty cycle. If the output values are consistent with the expected values then we proceed further else necessary corrections are made in the code. This is what is known as Behavioral Simulation. After several iterations of design and simulation the correct functionality is achieved. Once the design and simulation is done then another design review by some other people is done so that nothing is missed and no improper assumption made as far as the output functionality is concerned.

### Design Synthesis:

Post the behavioral simulation the design is synthesized. During simulation following takes place:

#### (i) HDL Compilation:

The tool compiles all the sub-modules of the main module. If any problem takes place then the syntax of the code must be checked.

#### (ii) HDL synthesis:

Hardware components like Multiplexers, Adders, Subtractors, Counters, Registers, Latches, Comparators, XORs, Tri-State buffers, Decoders are synthesized from the HDL code.

### 4.21- $\phi$ Half-Bridge MOSFET drive PWM Inverter:

Figure 4.2.1 shows the design circuit schematic and Figure 4.2.2 shows the design hardware of 1- $\phi$  Voltage Source Half-Bridge MOSFET drive PWM Inverter.

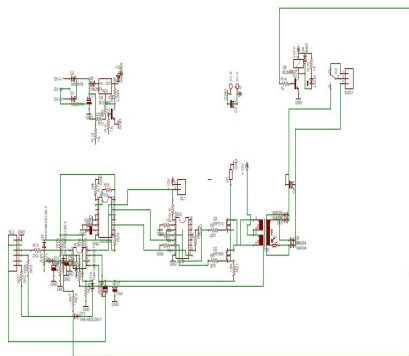

**Figure 4.2.1: Design Circuit Schematic**

There are 2 MOSFETs act as a switch (S1, S2). Both switches must be complementary to each other. (When S1 is closed, S2 must be opened and vice versa). Gate triggering pulse to both switches is a PWM signal coming from FPGA. The output of MOSFETs is connected to the center-tap transformer. The transformer is step-up type. The 12V DC is applied to the center terminal of the transformer. The output of the transformer is a square wave AC.

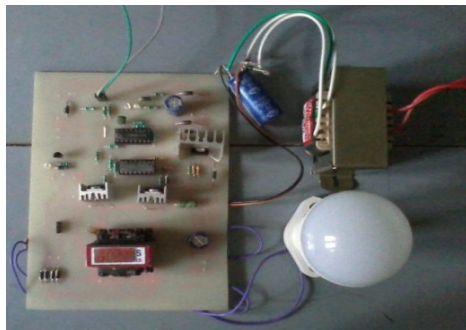

**Figure 4.2.2: Design 1- $\phi$  Voltage source half-bridge MOSFET based PWM Inverter**

### 4.3 Frequency Analysis:

We analyse the output for multiple frequencies ranging from 50 KHz to 1 MHz i.e. for different duty cycle (D).

$$\text{Duty Cycle (\%)} = \frac{t_{on}}{t_{on} + t_{off}} \times 100$$

Where, Ton = ON Time

Toff = OFF Time

T = Ton + Toff = Total Time

The frequency is applied to the VHDL code which is neuro-fuzzy based and then to the FPGA board. Thus, observe the simulation output waveform in ModelSim SE 6.3f and seen the synthesis output on a bulb by seeing the change in the intensity of light.

The simulation results for several frequencies are given below:

(a) **F = 100 KHz, T = 1000, Toff = 800, Ton = 200, D = 20%**

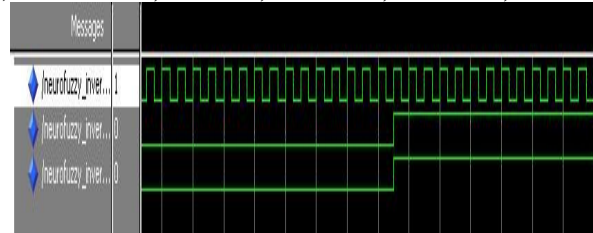

**Figure 4.3.1: Simulation Output for D = 20%**

(b) **F = 1000 KHz, T = 100, Toff = 75, Ton = 25, D = 25%**

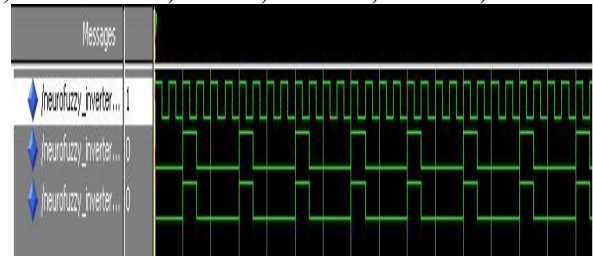

**Figure 4.3.2: Simulation Output for D = 25%**

## V. CONCLUSION

The project aims of design FPGA Implementation of Neuro-Fuzzy based 1- $\phi$  Half-Bridge MOSFET drive PWM Inverter for AC drive applications with emergency power was successful. The research represents one of pioneer efforts for applying intelligent control algorithms in control of AC drives based on the FPGA technology. The frequency analysis i.e. the changing duty cycle (D) helps us in improving and achieving our focus on designing an inexpensive, versatile and power efficient square wave inverter that gives a square wave AC output. Thus a viable solution to the emerging area of manufacturing ICs for drive applications using the novel FPGA technology was achieved.

## ACKNOWLEDGEMENT

This research project would not have been possible without the support of my mentor, guide, teachers and friends. I am thankful to all the individuals who encouraged and helped

me directly and indirectly to carry this work. Their continuous invaluable knowledgeable guidance throughout the course of this study helped me to complete the work up to this stage and hope will continue in further research.

## REFERENCES

- [1] Pankaj H Zope<sup>1</sup>, Pravin G.Bhangale<sup>2</sup>, Prashant Sonare<sup>3</sup>, S. R.Suralkar<sup>4</sup> "Design and Implementation of carrier based Sinusoidal PWM Inverter", International Journal of Advanced Research in Electrical, Electronics and Instrumentation Engineering, Vol. 1, Issue 4, Oct-2012
- [2] A. A. Mamun<sup>1</sup>, M. F. Elahi<sup>2</sup>, M. Quamruzzaman<sup>3</sup>, M. U. Tomal<sup>4</sup> "Design and Implementation of Single Phase Inverter" International Journal of Science and Research (IJSR), Volume 2 Issue 2, February 2013.
- [3] Ying-YU-TZOU, SHIN-LIANG JUNG, "Full Control of a PWM DC-AC for AC Voltage Regulation", IEEE Transactions on Aerospace & Electronic System, Vol. 34, No-4, October-1998
- [4] Shih-Liang Jung, Member, IEEE, Meng-Yueh Chang, Student Member, IEEE, Jin-Yi Jyang, Li-Chia Yeh, and Ying-Yu Tzou, Member, IEEE "Design and Implementation of an FPGA-Based Control IC for AC-Voltage Regulation", IEEE TRANSACTIONS ON POWER ELECTRONICS, VOL. 14, NO. 3, MAY 1999
- [5] N.A. Rahim and Z. Islam "Field Programmable Gate Array-Based Pulse-Width Modulation for Single Phase Active Power Filter", American Journal of Applied Sciences 6 (9): 1742-1747, 2009
- [6] Shanthi B., Natarajan S.P, "FPGA based Fuzzy Logic Control for Single Phase Multilevel Inverter APPLICATIONS", International Journal of Computer Applications (0975 – 8887) Volume 9– No.3, Nov-2010
- [7] Vivek Dutt, Rohtash Dhiman "Comparative Study of Direct Torque Control of Induction Motor Using Intelligent Techniques", Canadian Journal on Electrical and Electronics Engineering Vol. 2, No. 11, Nov-2011.
- [8] Inés del Campo, Associate Member, IEEE, Javier Echanobe, Member, IEEE, Guillermo Bosque, and José Manuel Tarela "Efficient Hardware Software Implementation of an Adaptive Neuro-Fuzzy System", IEEE TRANSACTIONS ON FUZZY SYSTEMS, VOL. 16, NO. 3, JUNE 2008.
- [9] Eftichios Koutroulis, Apostolos Dollas, Kostas Kalaitzakis, "High-frequency pulse width modulation implementation using FPGA and CPLD ICs", Journal of Systems Architecture 52 (2006) 332–344.
- [10] Ms. Anuja Murar Nazare, "FPGA BASED SINGLE PHASE MULTILEVEL INVERTER", Proc. of the Second Intl. Conf. on Advances in Computer, Electronics and Electrical Engineering -- CEEE 2013.
- [11] Muhammad H. Rashid, (2004): Power Electronics Circuits, Devices, and Applications'' Electrical computer Engineering University of west Florida.